



compactus[®]

INTRODUCTION

Side2Side 2 is the ideal system for transforming under-utilised areas such as alcoves into efficient storage space. It's simple; we just place a row of mobile shelving in front of a row of static shelving. This eliminates the need for permanent aisles as items stored are accessed from the front.

More accessible bays provide multiple 'picking faces', giving faster access for more operators to more stored items. Easily add to your Side2side 2 system should the need arise.

FEATURES

- Create an extremely efficient use of unconventional storage areas by mounting Ultima CI-80 shelving onto the attractive Side2side 2 track and runner system
- More accessible bays provide multiple 'picking faces', giving faster access for more operators to more stored items
- The innovative low profile track design provides great strength and enhanced mobility for the side to side base runners
- Attractive clip on track ramps further reduce trip hazards when accessing rear bays. The pivoting ramps allow a seamless transition between the flooring material and track
- The unique track based anti-tilt mechanism secures all shelving, further enhancing operator safety
- Easily upgrade from Dexion Office Ultima CI-80 shelving system

TECHNICAL SPECIFICATIONS

Drive Type Manual

Shelving & Accessory System Ultima CI-80

Maximum System Width Unlimited

Shelving Width (Bay Width)	750 mm
	900 mm
	1050 mm
	1200 mm

Shelving Depth	300 mm
	400 mm
	450 mm
	500 mm
	600 mm

Shelving Height	975 mm
	1875 mm
	2175 mm
	2400 mm

Overall System Heights	1040 mm
	1940 mm
	2240 mm
	2465 mm

Maximum Bay Carrying Capacity	500 kg
-------------------------------	--------

Maximum Movable Block Load	1000 kg
----------------------------	---------

Standard Colour*	Stone White
------------------	-------------

Anti-tilt System	Track & Runner
------------------	----------------

Warranty	10 Years
----------	----------

TYPICAL FLOOR PLAN

Overall Unit Depth

Lateral movement units are used in limited space situations, such as narrow rooms or corridors. The static bays comprise standard Ultima CI-80 static shelving, which sits on the floor, generally against a wall. The mobile units consist of individual 750, 900, 1050, or 1200mm wide bays, which move side ways on tracks and runners (trolley assemblies) in front of the static bays.

Note:

- In lateral installations, all mobile bays are individual single bays.
- The recommended clearance between front of the static unit roll posts and back panel or corner cover strip of mobile unit is 50mm.

Example Configuration - 900mm Static Bays and 750mm Mobile Bays

Number of 900mm static bays	2	3	4	5	6	7	8
Number of 750mm mobile bays	1	2	3	4	5	6	7

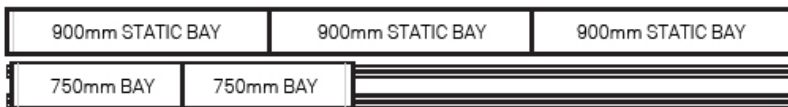

OTHER

Accessories	Ultima Shelf - Slotted Ultima Shelf - Plain Slotted Shelf Divider Plain Shelf Divider Filing Rack - Suspended Filing Rack - Wrap Around Roll Out File Frame Roll Out Media Drawer Roll Out Reference Shelf Hanging File Chassis
--------------------	--

*Please refer to the Dexion Office Colour Selector for a selection of available powder coat colours.

OVERALL DIMENSIONS

In installation, it is advised that the unit closest to a wall has a 50mm clearance away from the wall.

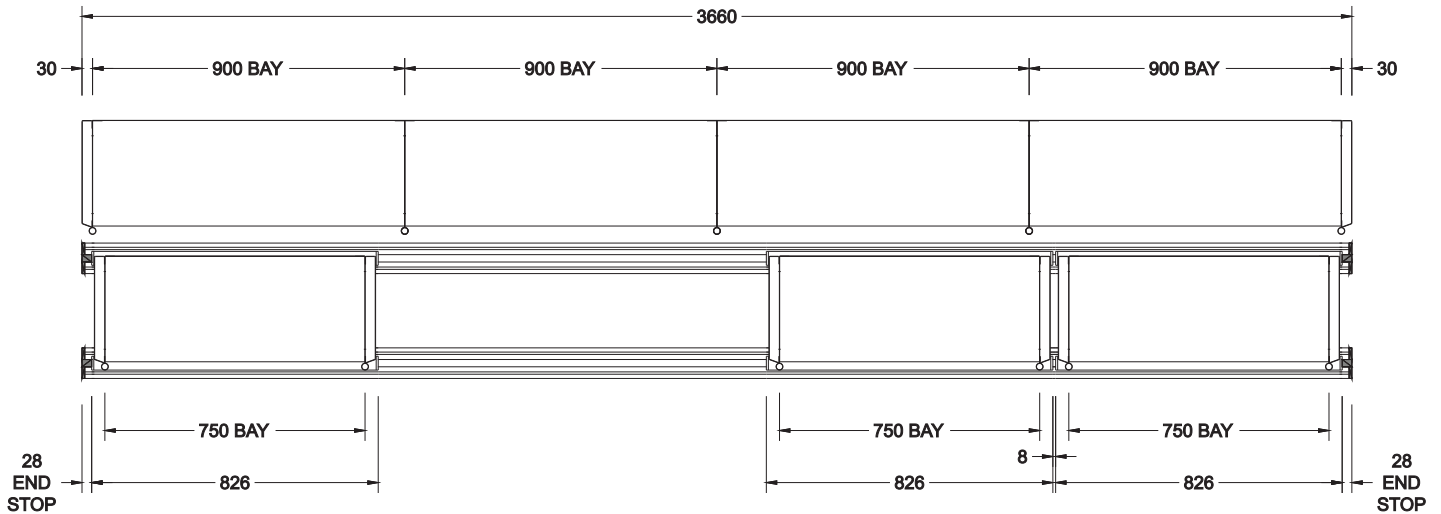

FLOOR LOADS

Please contact your Dexion Office representative for information relating to point loads exerted by the wheels on the tracks.

ENQUIRIES

For contact details, visit
www.dexionoffice.com.au
 Or call 1300 180 358

Ultima®, Compactus®, Freetrack® are registered trademarks.